

QL3B SINGLE HEAD

FILTER HEAD EXCLUSIVELY FOR
EVERPURE REPLACEMENT CARTRIDGES

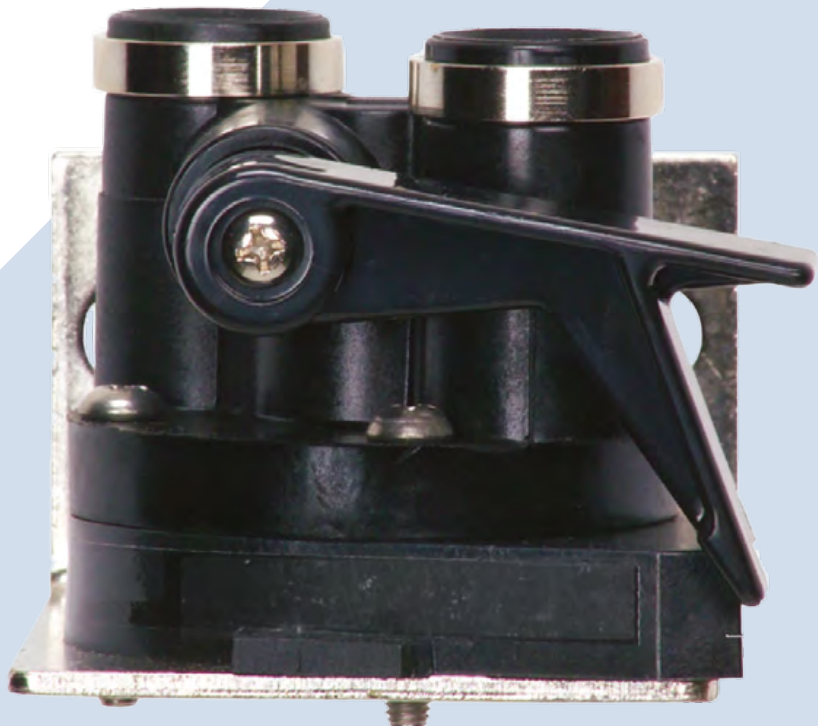

QL3B SINGLE HEAD

FILTER HEAD EXCLUSIVELY FOR EVERPURE REPLACEMENT CARTRIDGES

System Part Number: 4312-13

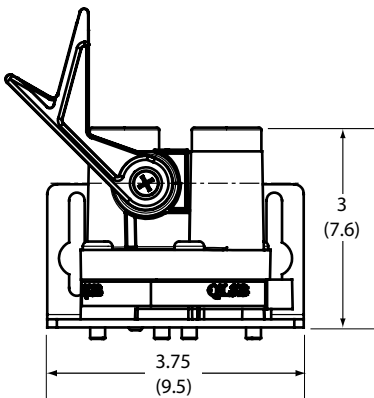

Features & benefits

- ▶ Commercial quality filter head is designed exclusively to fit Everpure filter cartridges
- ▶ Includes built-in water shutoff valve
- ▶ Includes mounting bracket and screws
- ▶ All wetted parts have passed NSF® extraction tests
- ▶ Corrosion resistant hardware
- ▶ Solid durable construction is ideal for Foodservice and vending applications
- ▶ Engineered for durability, strength and longevity

Specifications

- ▶ **Overall dimensions** 3" H x 3.75" W x 3.5" D (7.6 cm x 9.5 cm x 8.9 cm)
- ▶ **Electrical connection** None required

INSTALLATION TIPS

- ▶ Mounts directly onto flat surface
- ▶ Install vertically so cartridge hangs down
- ▶ Allow 2-1/2" (6.35 cm) clearance below the cartridge for easy cartridge replacement
- ▶ Flush filter by running water through filter according to cartridge instructions

OPERATION TIPS

- ▶ Change cartridges on a regular six (6) month preventative maintenance program
- ▶ Change cartridges when capacity is reached or when pressure decreases
- ▶ Always flush the filter cartridge at time of installation and cartridge change

APPLICATIONS

- ▶ Foodservice
- ▶ Vending machines
- ▶ Office coffee services