



► FROM PENTAIR WATER SOLUTIONS

EZ-RO™ 200/60L RVP EU REVERSE OSMOSIS SYSTEM

System Part Number: EV9975-81E



EZ-RO 200/60L wall mount



EZ-RO 200/60L with optional floor stand bracket



60L (10-gallon) hydropneumatic tank

SYSTEM DESCRIPTION

Leveraging proprietary technology, the EZ-RO 200/60L system uses Reverse Osmosis (RO) to reduce Total Dissolved Solids (TDS); it provides up to 757 L/day (200 gal/day)* and includes a 60-liter hydropneumatic tank. Ideal for applications where RO is necessary to meet manufacturer's warranty requirements†.

APPLICATIONS

- ◆ Combi ovens
- ◆ Steamers
- ◆ Proofers

FEATURES • BENEFITS

- ◆ Meets combi oven and steamer equipment water quality standards; known to significantly reduce scale and corrosion problems due to high TDS, water hardness*, and chlorides†
- ◆ 4CM cartridge provides optimal mineral content for proper function of conductivity sensors on steam equipment
- ◆ Sealed hydropneumatic storage tank provides capacity and pressurized water to downstream equipment
- ◆ Compact design allows installation under counters and in tight spaces
- ◆ Prefiltration with 4CB5-S reduces chlorine and extra fine dirt and particles as small as five (5) microns in size by mechanical means to help protect the RO membrane
- ◆ Pressure gauge allows monitoring of RO inlet pressure and prefilter condition
- ◆ Built-in bypass, sample port and flush valves speed up installation and cartridge replacement
- ◆ High flow 1/2" ID hose optimized water line to equipment
- ◆ Installation kit comes complete with tubing, fittings, and mounting hardware for installation; color coded parts and color photographs in manual makes installation easy
- ◆ High efficiency RO membrane saves up to two times more water than standard RO membranes‡
- ◆ Rotary vane pump driven by a 24VDC motor, featuring self priming and internal relief valve, ensures quiet operation, pulsation-free flow and a long service life

INSTALLATION TIPS

- ◆ Feed water connection to system—should be COLD only. Tempered water up to 80°F (26.6°C) can be used.
- ◆ Do not exceed system specifications for temperature and pressure.
- ◆ Provide a dedicated feed water supply connection of at least 3/8" inner diameter.
- ◆ Allow 3" clearance below system for filter cartridge removal and replacement.
- ◆ Detailed, illustrated installation guide is included with each system.

*Not performance tested or certified by NSF.

† When installed, serviced and maintained according to Pentair Everpure Installation Operation Instructions.

‡ Up to 50% recovery compared to standard RO systems with 25% recovery.

EPA Est. 002623-IL-003

EZ-RO™ 200/60L RVP EU REVERSE OSMOSIS SYSTEM

EV9975-81E

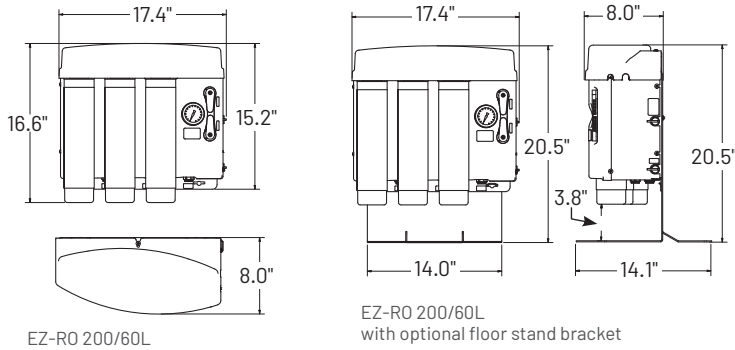

EZ-RO 200/60L

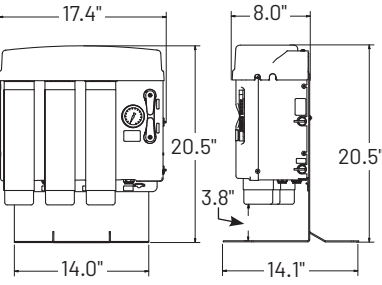

EZ-RO 200/60L
with optional floor stand bracket

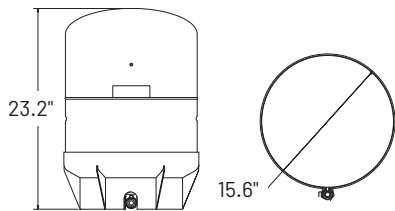

60L (10-gallon) hydropneumatic tank

SPECIFICATIONS

System	System
Overall Dimensions - Processor 16.6" H x 17.4" W x 8.0" D (42.2 cm x 44.2 cm x 20.3 cm)	Shipping Weight 49 lbs (22.3 kgs)
Tank Dimensions & Capacity 23.2" H x 15.6" DIA (58.9 cm x 39.6 DIA) 10 gallons (37.8 L)	Electrical Connection Schuko CEE 7/7 Plug UK BS1363A Plug
Connections Inlet: 3/8" push-to-connect Outlet: 1/2" OD push-to-connect; 3/4" garden hose connection included	Performance Daily Production Rate Up to 200 gpd (757 Lpd)* nominal at 77°F (25°C), 750 ppm NaCl, 60 psi (4.1 bar) feed water pressure*; production will vary based on water supply temperature and pressure
Pressure Requirements 50 - 100 psi (3.5 - 6.9 bar), non-shock	Service Flow Rate Dependent on water level and pressure in storage tank
Water Temperature 40-100°F (4 - 38°C)	

*Not performance tested or certified by NSF.

OPTIONS

Model	Description	Part No
PRV	Pressure reducing valve	164-89938
Air Gap Kit	Air gap approved for drain	164-89905
EZFS	Floor stand bracket	EV3159-68
Mixing Valve	Thermostatic mixing valve	EV3114-79

REPLACEMENT CARTRIDGES

Model	Qty	Description	Part No
4CB5-S	1	Prefilter	EV9617-21
EZ-200	1	RO membrane	EV9628-92
4CM	1	Mineral addition	EV9627-80

It is recommended that pre-/post-filters and mineral addition cartridges are changed every six (6) months, when capacity is reached, or when feed water pressure or flow becomes inadequate.

The contaminants or other substances removed or reduced by this drinking water system are not necessarily in your water. Do not use with water that is microbiologically unsafe or of unknown quality without adequate disinfection before or after the system.

Since the conditions under which our products may be used are beyond our control, we cannot accept any liability with respect to the improper installation, application and/or use of our products.

For Pentair Patent Information visit:
<http://pentair.com/patents>



United States | 1040 Muirfield Drive | Hanover Park, IL 60133 | 800.942.1153 (US Only) 630.307.3000 Main | cseverpure@pentair.com | foodservice.pentair.com
 Australia | 1-21 Monash Drive | Dandenong South, Vic 3175 | Australia | 011.1300 576 190 Tel | au.everpure@pentair.com
 China | 21F Cloud 9 Plaza, NO 1118 | Shanghai, 200052 | China | 86.21.3211.4588 Tel | china.water@pentair.com
 India | Boulevard, B-9/A, 7th Floor - Tower B Sector 62 | Noida - 201301 | 91.120.419.9444 Tel | indiacustomer@pentair.com
 Europe | Pentair Water Belgium BV | Industriepark Wolfstee, Toekomstlaan 30, B-2200 Herentals | Belgium | +32.(0).14.283.504 Tel | foodservice.eu@pentair.com
 Japan | Japan Inc. | Hashimoto MN Bldg. 7F, | 3-25-1 Hashimoto, Midori-ku, Sagami-hara-shi | Kanagawa 252-0143 | Japan | 81.(0)42.775.3011 Tel | info@everpure.co.jp
 Southeast Asia | 390 Havelock Road, | #04-01 King's Centre | Singapore 169662 | 65.6768.5800 Tel | cseverpure@pentair.com

All indicated Pentair trademarks and logos are property of Pentair. Third party registered and unregistered trademarks and logos are the property of their respective owners.