

CLARIS XXL - LARGE FILTER CARTRIDGE

ADJUSTABLE ION-SELECTIVE FILTERS TO TAILOR
CARBONATE HARDNESS LEVELS IN POTABLE WATER

CLARIS XXL-LARGE FILTER CARTRIDGE:
EV4339-14



Head sold separately

APPLICATIONS

- ◆ Coffee
- ◆ Espresso
- ◆ Hot Drink Vending
- ◆ Combi Steamers
- ◆ Self-Cooking Systems
- ◆ Steam Cookers and Ovens
- ◆ Brewed Iced Tea

FEATURES • BENEFITS

- ◆ Five-stage filtration process:
 - Prefiltration
 - Carbonate hardness adjustment*
 - Fine filtration*
 - Highly efficient carbon block
 - Solid membrane filter
- ◆ Removes harmful contaminants and unpleasant odors and tastes
- ◆ Removes particles down to five (5) micron for highest equipment protection*
- ◆ Operates in vertical or horizontal position

*Not performance tested or certified by NSF® International

INSTALLATION TIPS

- ◆ The system can be operated freestanding, horizontally or vertically.
- ◆ Water pressure at the filter system inlet must not exceed 8 bar. A pressure reducer valve must be installed on the water supply side of the filter system if the inlet pressure exceeds 8 bar.
- ◆ Shut-off valve must be installed upstream of the filter.
- ◆ Refer to installation, operation & maintenance manual for cartridge flushing and startup.

OPERATION TIPS

- ◆ Change Claris Cartridges when its pre-calculated water volume has been reached or at least once per year.
- ◆ Change cartridges when capacity is reached.
- ◆ Always flush the filter cartridge at time of installation and cartridge change.
- ◆ Do not use hardness test strips to check for hardness reduction. Please use Titration Kit to check for hardness reduction.

SIZING

- ◆ Service Flow Rate: 3.7 Lpm
- ◆ Capacity:
11,000 L for espresso*
13,200 L for OCS/Coffee*

**This capacity if based on influent water hardness of 180 ppm with standard bypass settings. For steam applications and other hardness levels consult installation and operations guide capacity and bypass settings charts.*

CLARIS XXL LARGE FILTER CARTRIDGE

EV4339-14



CLARIS LARGE FILTER CARTRIDGE: 4339-12

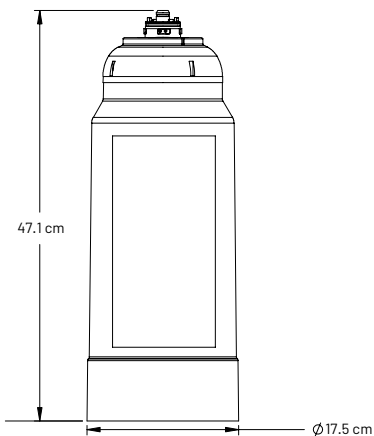

The contaminants or other substances removed or reduced by this drinking water system are not necessarily in your water. Do not use with water that is microbiologically unsafe or of unknown quality without adequate disinfection before or after the system.

SPECIFICATIONS

- ◆ **Overall Dimensions**
47.1 x 17.5 cm dia
- ◆ **Rated Capacity**
11,000 L for espresso*
13,200 L for OCS/Coffee*
- ◆ **Service Flow Rate**
3.7 Lpm
- ◆ **Pressure Requirements**
2 – 8 bar, non-shock
- ◆ **Temperature Limits**
4 – 30°C
- ◆ **Electrical Connection**
None required

*This capacity is based on influent water hardness of 180 ppm with standard bypass settings. For steam applications and other hardness levels consult installation and operations guide capacity and bypass settings charts.

WARRANTY

Everpure Claris by Pentair water treatment systems are covered by a limited warranty against defects in material and workmanship for a period of one year after date of purchase. Everpure replaceable elements (filter cartridges and water treatment cartridges) are covered by a limited warranty against defects in material and workmanship for a period of one year after date of purchase. See printed warranty for details. Pentair will provide a copy of the warranty upon request.